

TABLE OF CONTENTS

A. SAFETY GUIDELINES.....	1
B. INTRODUCTION.....	2
C. ASSEMBLING YOUR CYCLE	
List of parts.....	3
Step by step instructions.....	4
Floor level adjustment.....	8
D. EXERCISING ON YOUR CYCLE	
Understanding the Electronics Package.....	9
Set.....	9
Choosing between Program and Manual mode.....	10
Manual.....	10
Mode (What each of these categories means)	10
INTERVAL.....	11
PROGRAM.....	12
E. KEY FUNCTIONS	
▲ Up/ ▼ Down.....	13
Enter/Mode.....	13
Reset.....	13
F. MAINTAINING YOUR CYCLE	
Cleaning The Cycle.....	14
G. TROUBLE SHOOTING	
Blank Display.....	15
No Tension.....	16
No "RPM" Reading.....	16

Sports Art- 5005B/5005H upright cycle

SAFETY GUIDELINES:

Please read and follow the following safety guidelines:

- . Read this owner's manual and follow the instructions.
- . Always unplug the cycle from the electrical outlet immediately after using and before cleaning.
- . Assemble and operate the cycle on a solid, level surface.
- . Never allow children on or near the cycle.
- . Check the cycle before every use. Make sure all parts are assembled, and all nuts and bolts are tightened. Do not use the cycle if the unit is disassembled in any way.
- . Keep your hands away from moving parts.
- . Wear proper workout clothing: do NOT wear loose clothing. Do not wear shoes with leather soles or high heels. Tie all long hair back.
- . Don't rock the unit from side to side, and use care when mounting and dismounting the unit.
- . Don't stand on the unit.
- . Do not use any accessories that aren't specifically recommended by the manufacturer these might cause injuries or cause the unit to fail.
- . Work within your recommended exercise level do NOT work to exhaustion.
- . If you feel any pain or abnormal sensations, STOP YOUR WORKOUT and consult your physician immediately.

Caution:

Before beginning any exercise program, you should consult with your doctor. It is recommended that you undergo a complete physical examination.

INTRODUCTION:

Congratulations on purchasing one of the finest pieces of exercise equipment on the market today. Constructed of high quality materials and designed for years of troublefree usage, you will find the unit very easy to assemble and use.

Before using your cycle, we recommend that you familiarize yourself with this Owner's Manual. Whether you are a first time user of an exercise cycle or a seasoned "pro," understanding the correct use of the equipment will enhance your ability to achieve your exercise goals safely and successfully.

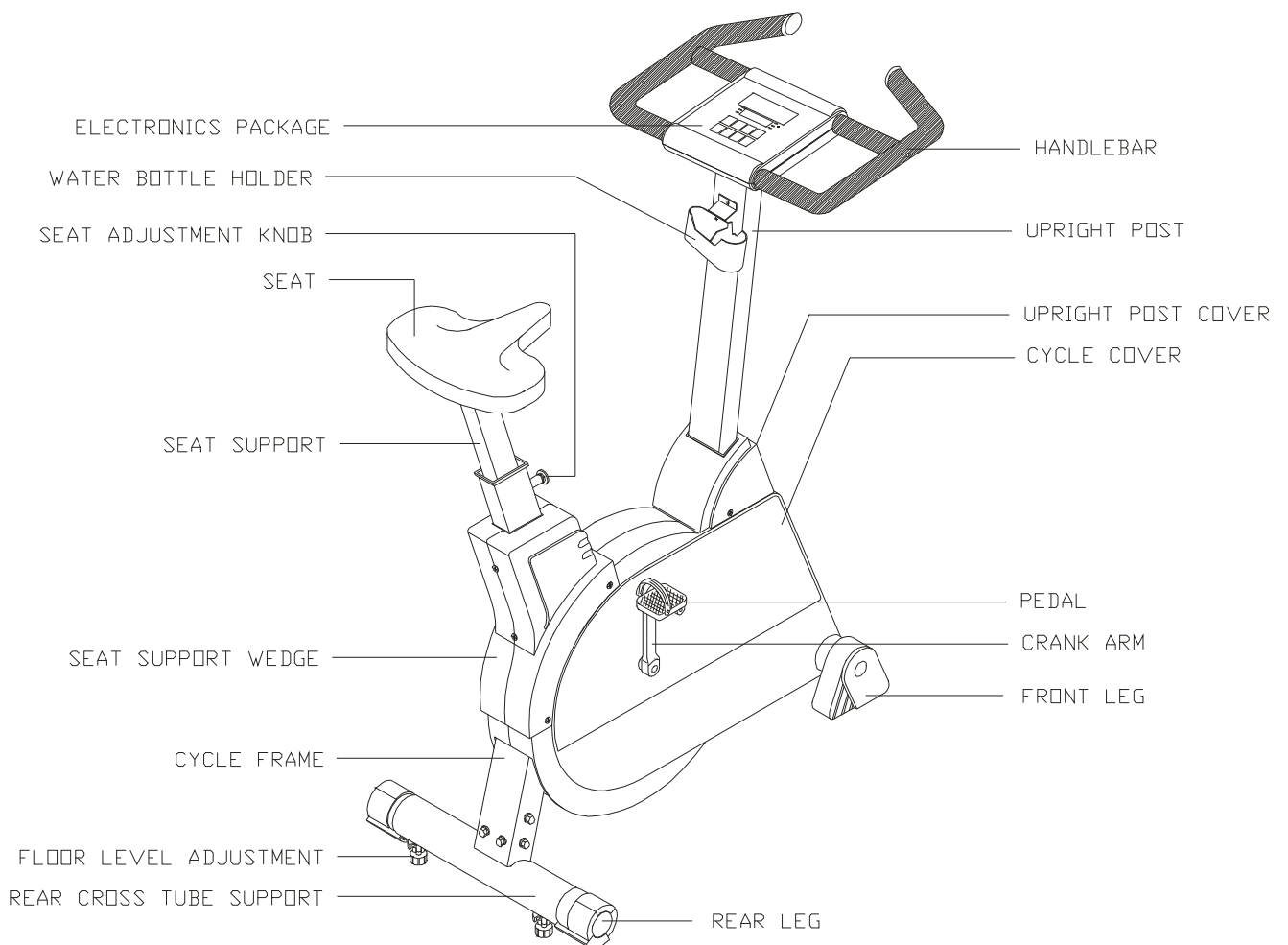

ASSEMBLING YOUR CYCLE:

List of parts:

- . Six 5/16"x 3/4" bolts - Rear cross tube support
- . Six 5/16" Spring washers - Rear cross tube support
- . Six 5/16" flat washers - Rear cross tube support
- . Four 5/16"x 3/4" bolts - Upright post
- . Four 5/16" Spring washers - Upright post
- . Four 5/16" flat washers - Upright post
- . Two Philip screws - Upright post cover
- . One pair of foot pedals
- . One set of screw drivers
- . One hex allen wrench
- . One combination wrench
- . One spare 1A fuse

Step by step instructions

Before assembling your cycle, make sure that you have all the above parts. The following steps explain how to assemble your exercise cycle. Please read every step thoroughly, and follow the directions completely to ensure correct assembly.

1. Make sure all packing materials are removed from the cycle frame.
2. Place the cycle on a level, flat surface.
3. Place the end of the cycle frame over the rear cross tube support. Attach the cycle frame to the rear cross tube support using two bolts, two spring washers and two flat washers on each side. Make sure that the front and rear legs sit flat on the floor before tightening the bolts securely (see Fig. 1).

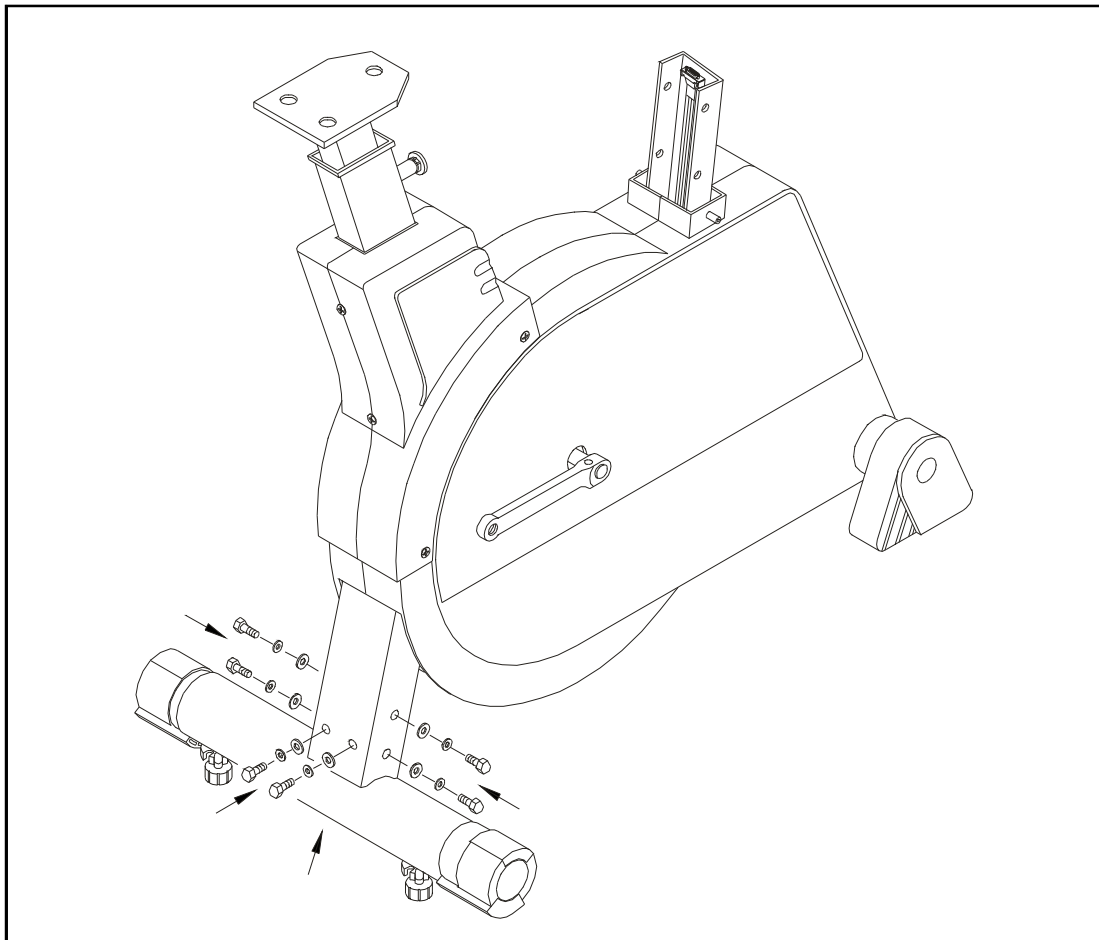

(FIG.1)

4. Attach the handlebar mounting plate to the cycle frame, using four bolts, four spring washers and four flat washers. Tighten the four bolts securely (see Fig. 2).

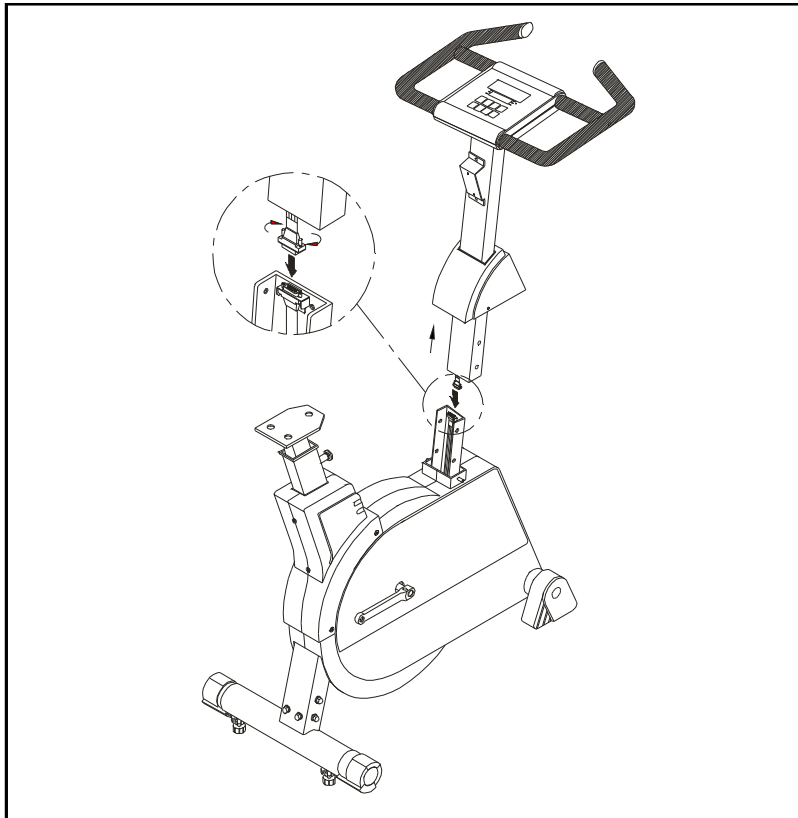

(FIG.2)

WARNING: MAKE SURE THE CONNECTOR IS PUSHED SECURELY INTO ITS SOCKET TO AVOID DAMAGE TO THE CONTROL BOARD.

5. Insert the upright post into the cycle frame, using two bolts, two spring washers, two flat washers on each side. Then tighten the bolts securely (see Fig. 3).

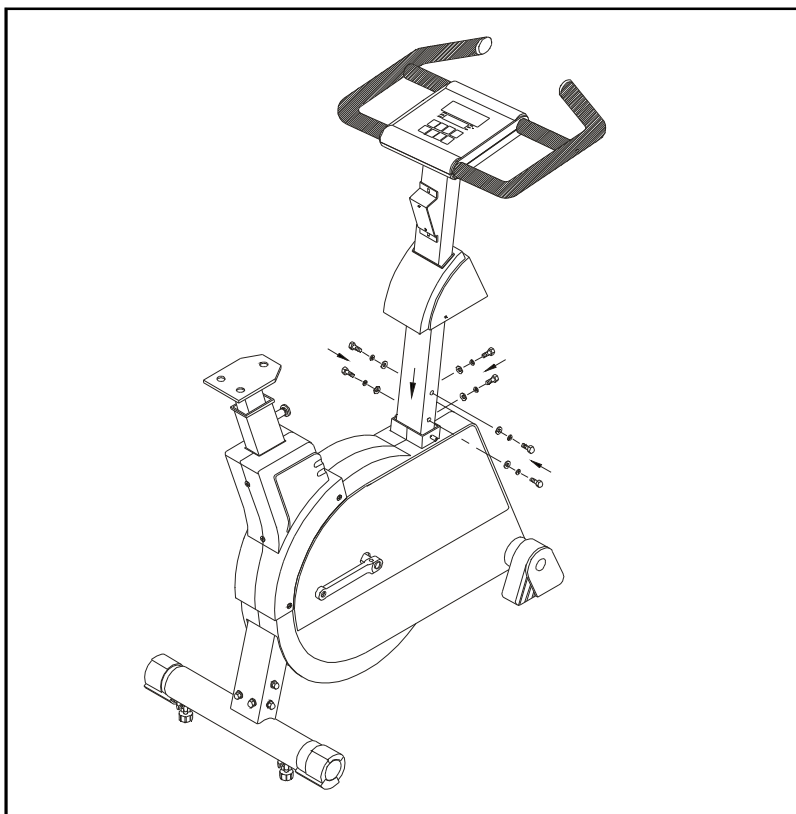

(FIG.3)

6. Attach the upright post cover to the front of cycle, using two Phillips screws, one for each side (see Fig. 4).

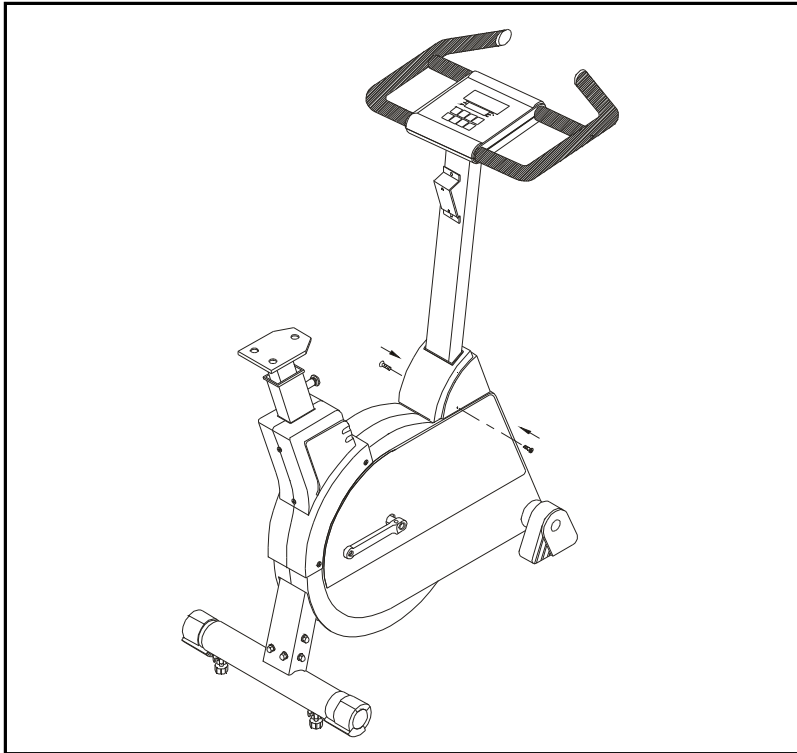

(FIG.4)

7. Attach the foot pedals to the crank arms on the cycle. Be careful to install the pedals on the correct crank arm. Use a combination wrench to tighten the pedals securely (see Fig.5)..

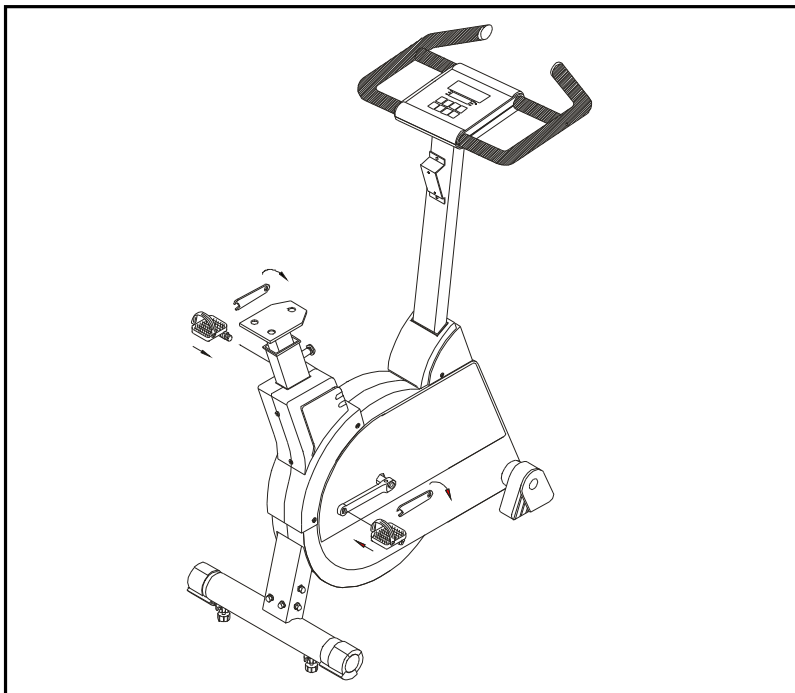

(FIG.5)

A "R" or "L" on the foot pedal indicates the correct side. Install the pedal marked "R" on the right-hand crank arm (as you stand at the rear of the cycle facing front). When you install the pedal on the left hand crank arm, rotate the pedal counterclockwise to tighten since the pedal has left-hand screw threads.

- Place the cycle seat to the seat support, tighten with three bolts, three spring washers from underneath the seat (see Fig.6).

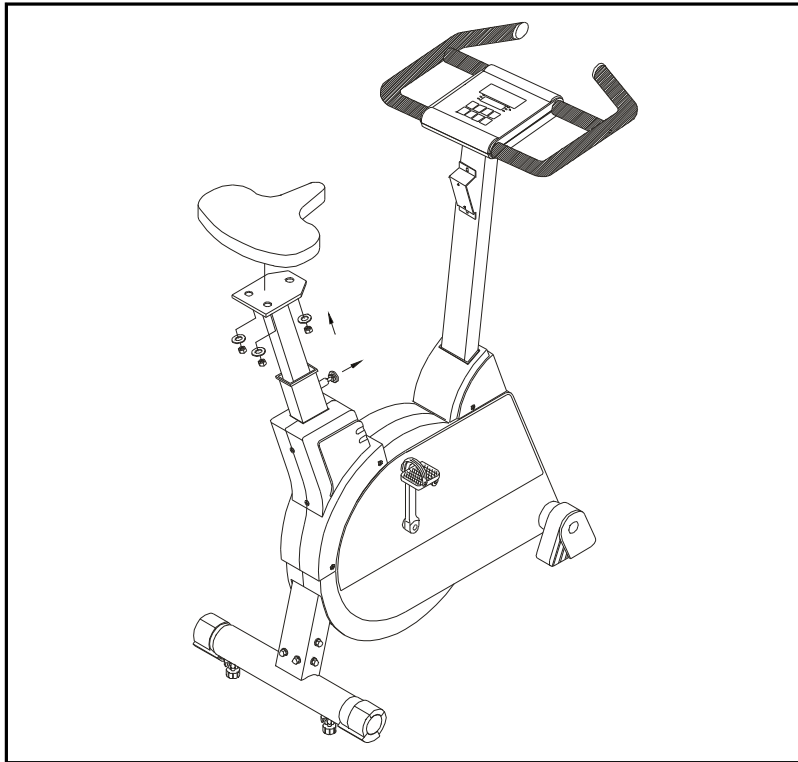

(FIG.6)

To move the seat support up or down, pull on the seat adjustment knob for adjusting to your desired position.

- Assemble the water bottle/personal stereo holder to the right front post using the screws provided (see Fig. 7).

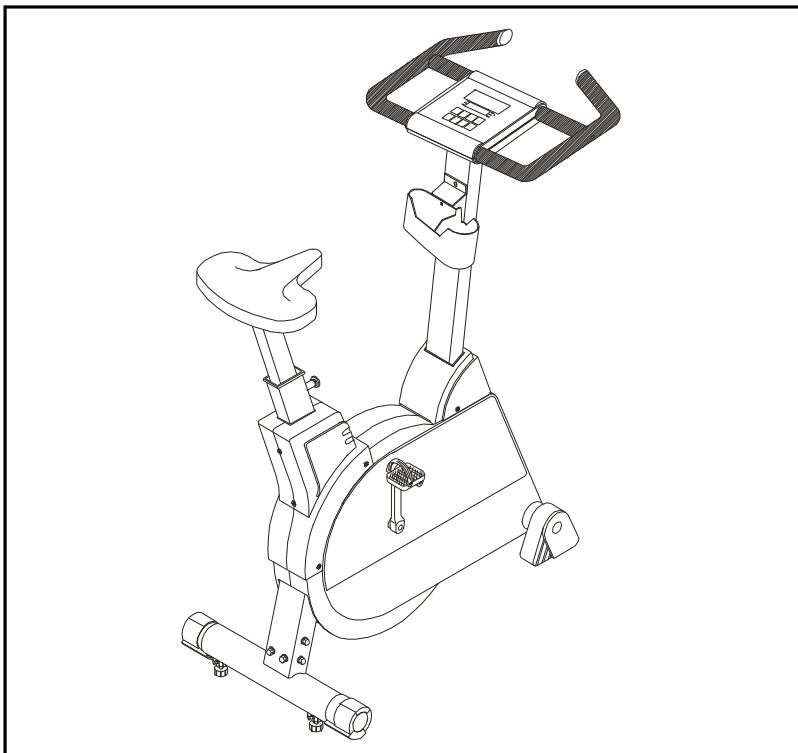

(FIG.7)

Floor level adjustment

If the cycle is unsteady on your floor, turn the floor level adjustment either on the rear feet or at the front of cycle. Raise or lower the floor level adjustment to steady your cycle (see Fig. 8).

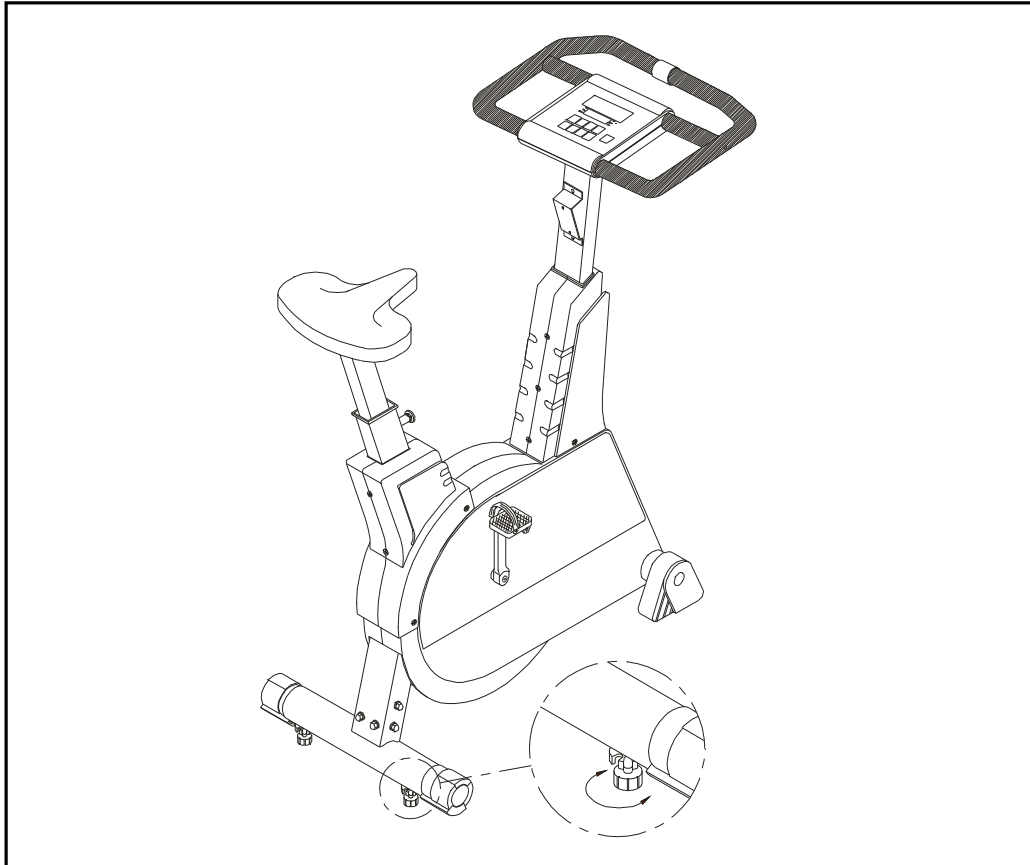

(FIG.8)

EXERCISING ON YOUR CYCLE:

Understanding the ELECTRONICS PACKAGE

The electronics package lets you control your workout. It is designed for safely and easy to use. You may simply press the Enter/Mode key at any time and follow the scrolled message. If you do not press Enter/Mode to enter your selection, after 5 seconds the display will remind you with "PRESS ENTER". This reminder continues to scroll across the display every 5 seconds until Enter/Mode pressed.

1. Plug the POWER CORD into the electrical outlet, then turn the power switch to "I" (on) position.
2. The legend "Mile & 130 LB" or "Kilo & 60 KG" will scroll from right to left across the screen, followed by "Press ▲▼ to Select Course" and "MAN'L" on screen.
3. Use the ▲ or ▼ key to select either "Set", "MAN'L", "INTV" or Programs 1 through 6.

SET:

1. Use the ▲ or ▼ key to select "Set", then press "Enter/Mode". And the read out will display "press ▲▼ to select Mile or Kilo". Once you have set, press "Enter/Mode" to save your selection.

Note: Choosing Mile will automatically select pounds in the weight calculation, and choosing Kilo will automatically select kilograms in the weight calculation.

2. To enter your weight, wait until "Enter Weight" scrolls across the screen. The numbers will start at either "130LB" or "60KG". Use the ▲▼ to set the desired weight.

The range of the display is from 50 LB to 250 LB, or 22 KG to 114 KG.

Once you have set the desired weight, press "Enter/Mode". This will allow the unit to calculate calorie expenditure.

Your selection is retained in memory even when the unit is turned off, or unplugged. You may reprogram your selection by repeating these steps.

Choosing Between PROGRAM And MANUAL Mode:

After your weight is set, the screen will read "MAN'L". Pressing an ▲ key will scroll through "PRO 1-6", "MAN'L" and "INTV".

Once you have set your desired program, then press Enter/Mode.

MANUAL:

You can use the Enter/Mode key to switch to LEVEL (or WATTS), PACER/RPM, DISTANCE, CAL., TIME, SCAN or PULSE. Use the ▲▼ keys to set the desired load, TIME or DISTANCE.

MODE (What each of these categories means):

SCAN: Pressing the "SCAN" key will result in the display alternating between Mode readouts every 4 seconds.

TIME: The range available in TIME mode is 00:00-99:59 minutes. Use the ▲ or ▼ key to set the desired time.

The electronics package will beep for 10 seconds when your desired time is reached, then will start to count up if your workout continues.

CAL: This readout gives you the amount of calories burned per minute, based on the weight entered and distance/load ridden.

The range of calories is from 0-999.9 KCAL.

DIST: The distance of the cycle will register goes from 0-99.00 miles or 0-999.9 kilometers. Use the ▲ or ▼ key to set the desired distance.

Each press of the key changes the distance by 0.05 mile (0.1 km). If you hold down the key, the numbers will increase or decrease by 0.5 miles or 1 km every .5 seconds.

PACER/REM:

A sensor counts the number of revolutions the flywheel makes in one minute, and this is displayed on the screen.

The range for RPM is 0-999.

LOAD (There are two expression of load):

LEVEL: There are 14 levels, with Level 1 being the lightest, and LEVEL 14 being the heaviest. Use the ▲▼ keys to chose the desired level.

WATTS: The watts range from 50-320 watts, with the watts 50 being the lightest, and the watts 320 being the heaviest. Use the ▲▼ keys to chose the desired watts.

PULSE: If your electronics package included a pulse meter to monitor your heart rate either measure by fingertip or earlap. This meter readout measures your heart rate per minute, with a range of 0-999.

INTERVAL:

1. Use the ▲▼ keys to chose the INTV mode, then press Enter/Mode, the LED will display the message: "PRESS ▲▼ TO SET REST LEVEL (or WATTS). "
2. Adjust the desired load using the ▲▼ keys. Then press ENTER.
3. Next, the LED will display the message: "PRESS ▲▼ TO SET REST TIME". Select the desired REST time (second), then press ENTER.
4. After the REST level have been set, the display will read "PRESS ▲▼ TO SET WORK LEVEL (or WATTS). " Adjust the desired load using the ▼ keys, then press "Enter/Mode". If you don't press the "ENTER" key , the display will remind you to press the "ENTER" key.
5. The cycle will automatically adjust the load according to your entered preferences. The lower LED lights indicates the REST load, the height of the LED lights indicates the variations in WORK load, the load workout alternating between the REST and WORK every minute.

The numbers on the right indicate the time remaining for the current segment.

When the REST interval is over, the display will show "GOING TO WORK LOAD", and the machine will adjust to the settings you chose for the work interval. When the WORK time is over, the display will show "GOING TO REST LOAD ", and return to the settings you chose for the rest interval.

6. You can change the level (or watts) at any time during the workout.

PROGRAM:

1. Use the ▲▼ keys to chose between Programs 1-6, then press "Enter/Mode" when they are displayed. When you press the Program of your choice, you must select either the DIST or the TIME.

Use the ▲ or ▼ key to set the desired distance or time. After you have set this, press "Enter/Mode". Your choice will be followed by a graph of the program itself. After you have set this, start to pedal the cycle and the program will begin after the third revolution.

2. The program will advance in line increments, scrolling from right to left across the screen every 30 seconds, the electronics package will automatically SCAN through the various Modes, then return to the program display.

—
—

—
—

—
—

—
—

—
—

—
—

KEY FUNCTIONS:

▲ UP/ ▼ DOWN: These keys are used to choose the desired TIME, DIST, MILE/KILO as well as to choose SET, MAN'L, INTV or PROGRAM 16.

In PROGRAM Mode, they are used to set the TIME or the DISTANCE.

ENTER/MODE: After setting a preference, press these key to record and save your choice.

RESET: After choosing either PROGRAM, INTV or MAN'L. pressing this key will return the display to the other selection (e.g. If you choose MAN'L. then change your mind, press RESET and the display will return to "Press ▲▼ To Select Course".

MAINTAINING YOUR CYCLE

This cycle requires little maintenance. The cycle's low friction operation is dependent on keeping the unit as clean as possible. See "Cleaning the cycle" for more information.

Cleaning The Cycle

CAUTION: Turn off unit and disconnect AC cord before cleaning.

Regular cleaning is recommended to keep your cycle at peak performance.

Before your workout, use a dry cloth to clean the surface of the electronics package.

Note: Never pour liquids on the electronics package. Should water, for some reason, get on the electronics package, immediately blow dry the electronics package.

To clean the plastic parts, use a mild detergent and make sure the unit is completely dry before operating.

It is recommended that you keep all liquids away from the unit during operation. Spillage of liquids onto or into the machine will void the warranty.

TROUBLE SHOOTING:

A. Blank Display:

1. If you turn on the POWER switch and the switch is not lit:

- a. Check if the power cord is plugged securely into the wall socket.
- b. After the above step performed, if the power switch is still not lit, replace a new fuse.

CAUTION: Make sure to unplug the power cord from the wall socket before replacing the fuse.

To remove:

Find the 1A fuse holder on the front of the machine, push on the fuse holder and turn the fuse holder counterclockwise to remove the damaged fuse (see Fig.9-1~9-2)

To install:

Insert a new fuse into the holder. Push the fuse and holder in, and then turn clockwise to secure the fuse holder (see Fig.9-3~9-4).

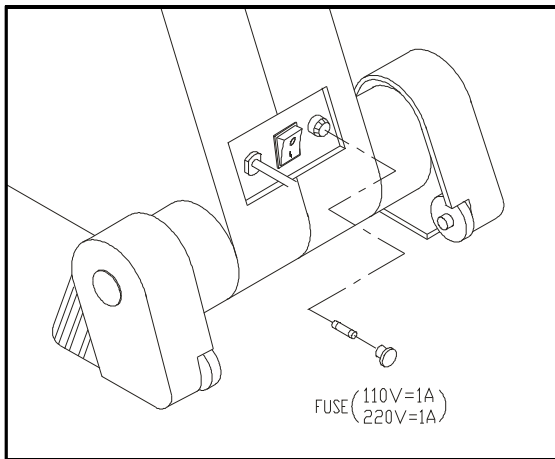

Fig.9-1

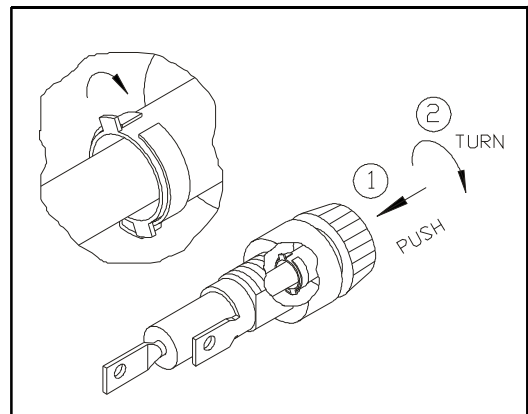

Fig.9-2

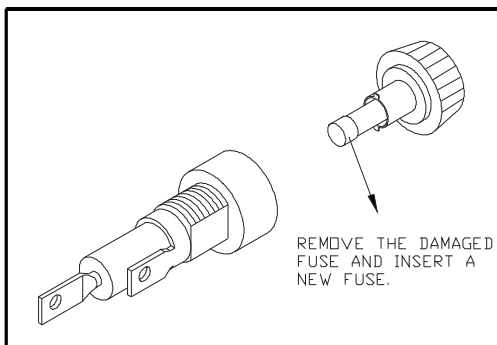

Fig.9-4

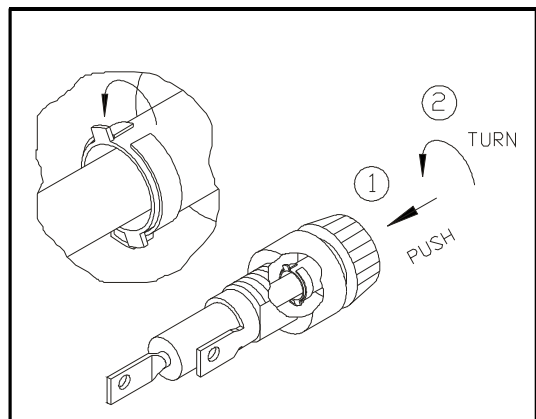

Fig.9-3

- c. Plug the power cord into the wall socket and turn on the machine again. If the power switch is still not lit, please contact your dealer for more information.
2. If you turn on the power switch and the switch is lit, but there is no display, please contact your dealer for more information.

B. No Tension:

If there is no tension while pedaling, please contact your dealer for more details.

C. No "RPM" Reading:

If your display has no "RPM" reading while you are pedaling, please contact your dealer for more details.

Wiring Schematic:

